

ST-315SBC

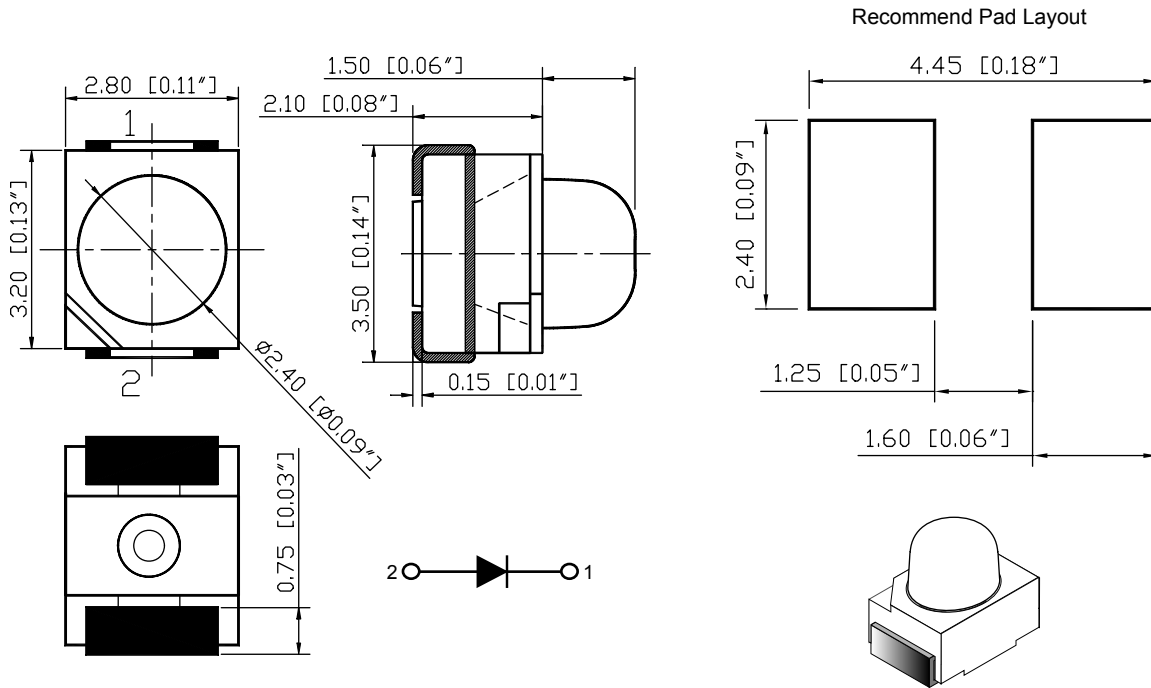

Dice	Blue (GaInN)	Lens Type	Water transparent
------	----------------	-----------	-------------------

Absolute Maximum Rating at (Ta=25°C)

Parameter	Symbol	Maximum Rating	Unit
Power Dissipation	Pd	111	mW
Forward Current	If	30	mA
Peak Forward Current Per chip *	Ifp	125	mA
Operating Temperature Range	Topr	- 40 °C to + 85 °C	
Storage Temperature Range	Tstg	- 40 °C to + 85 °C	
Solder Temperature 1/16 Inch Below Seating Plane for 3 seconds at 260°C			

* Condition for Ifp is pulse of 1/10 Duty Cycle, 0.1ms Pulse Width

Electrical/Optical Characteristics at Ta=25°C

Parameter	Symbol	Condition	Min	Typ	Max	Unit
Forward Voltage	Vf	If=20mA	2.8		3.7	V
Reverse Current	Ir	Vr=5V			10	uA
Luminous Intensity	Iv	If=20mA	630	880		mcd
Spectrum With of Half Value	Δλ	If=20mA		25		nm
Wavelength	λp	If=20mA		465		nm
	λd	If=20mA	465	470	475	nm
Viewing Angle	2Θ1/2			30		0°

NOTES: 1. All dimensions are in millimeter (inches), tolerance is 0.25 unless otherwise noted.
2. Specifications are subject to change without notice.