

# ST-313HWC

Package Dimensions

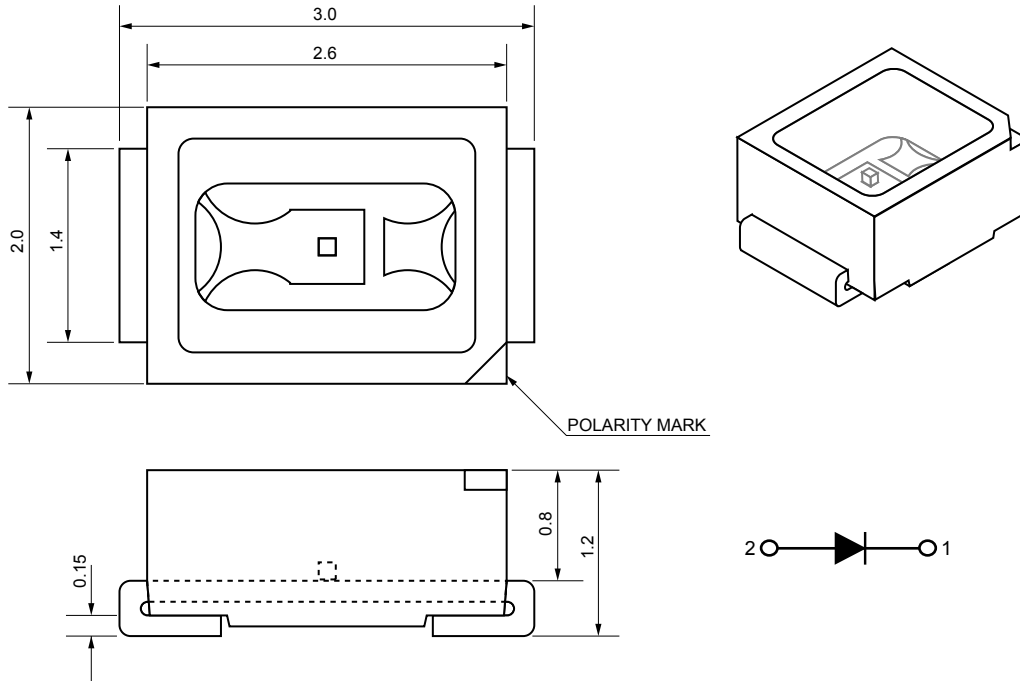

Dice	White (InGaN)	Lens Type	Yellow Diffused
------	---------------	-----------	-----------------

Absolute Maximum Rating at (Ta=25°C)

Parameter	Symbol	Maximum Rating	Unit
Power Dissipation	Pd	114	mW
Forward Current	If	30	mA
Peak Forward Current Per chip *	Ifp	150	mA
Operating Temperature Range	Topr	- 40 °C to + 85 °C	
Storage Temperature Range	Tstg	- 40 °C to + 85 °C	
Solder Temperature 1/16 Inch Below Seating Plane for 3 seconds at 260°C			

\* Condition for Ifp is pulse of 1/10 Duty Cycle, 0.1ms Pulse Width

Electrical/Optical Characteristics at Ta=25°C

Parameter	Symbol	Condition	Min	Typ	Max	Unit
Forward Voltage	Vf	If=20mA	3.0	3.2	3.6	V
Reverse Current	Ir	Vr=5V			5	uA
Luminous Intensity	Iv	If=20mA	1200	1700		mcd
Wavelength	X	If=20mA		0.29		nm
	Y	If=20mA		0.30		nm
Viewing Angle	2Θ1/2			120		0°

NOTES: 1. All dimensions are in millimeter (inches), tolerance is 0.25 unless otherwise noted.  
2. Specifications are subject to change without notice.