

**ST-312**

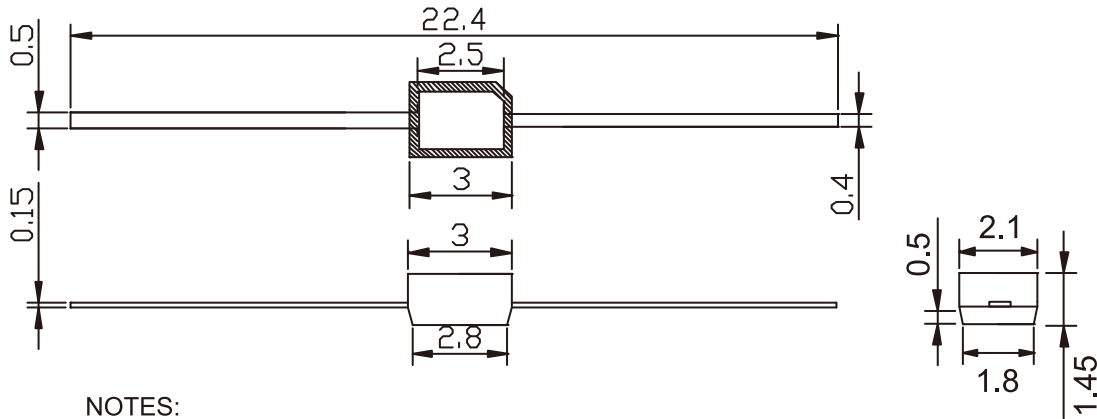

**NOTES:**

- 1: All dimensions are in millimeters (inches);
- 2: Tolerances are +/- 0.2mm (0.008inch) unless otherwise noted.

Item	Materials
Resin	Epoxy
Bonding wire	Ø 30 um Au
Lens color	Diffused
Dice	AllnGaN
emitted color	White

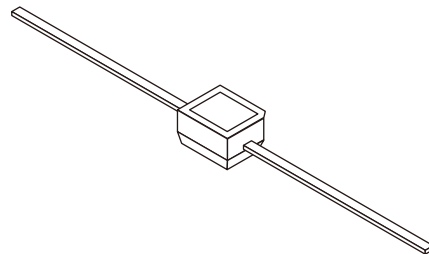

Absolute maximum ratings(Ta=25°C)

Parameter	Symbol	Value	Unit
Forward current	If	20	mA
Reverse voltage	Vr	5	V
Power dissipation	Pd	70	mW
Operating temperature range	Top	-20~+80	°C
Storage temperature range	Tstg	-20~+80	°C
Peak pulsing current (1/8 duty f=1kHz)	Ifp	100	mA

Electro-optical characteristics(Ta=25°C)

Parameter	Test Condition	Symbol	Value			Unit
			Min	Typ	Max	
Forward voltage	If=5mA	Vf	2.7	\	3.5	V
Luminous intensity	If=5mA	Iv	\	500	600	ucd
Viewing angle at 50% Iv	If=10mA	2Θ 1/2	\	110	\	Deg
Reverse current	Vr=5V	Ir	\	\	10	uA

	Chromaticity			
	Top	Left	Bottom	Right
<b>x</b>	0.26	0.24	0.24	0.27
<b>y</b>	0.28	0.24	0.23	0.25

- NOTES: 1. All dimensions are in millimeter (inches), tolerance is 0.25 unless otherwise noted.
- 2. Specifications are subject to change without notice.