

R12W(1.0)

Features

- * 1w Power LED
- * Size: dia. 20mm
- * DC input
- * Indoor / Outdoor use
- * Saving energy
- * Good illumination intensity
- * Full range of colors
- * Wide viewing angle
- * Long life more than 60,000hrs
- * Well heat sink
- * RoHs Compliant

Part No.		R12W(1.0)
Lens		Water Clear
Chip	Ram Material	GaN
	Emitted colour	White

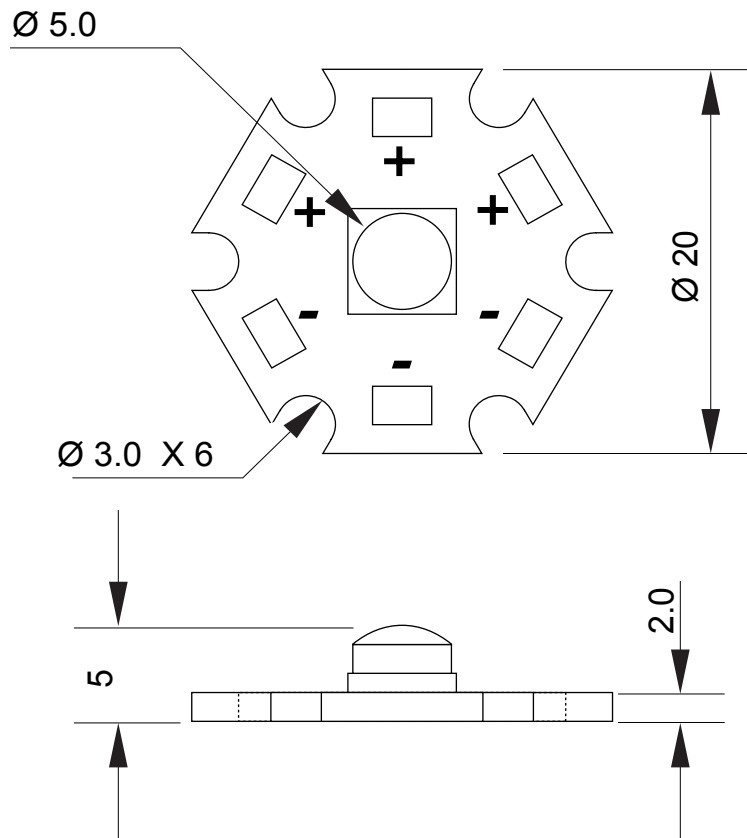

NOTES: 1. All dimensions are in millimeter (inches), tolerance is 0.25 unless otherwise noted.
2. Specifications are subject to change without notice.

Absolute Maximum Rating: (TA=25°C)

Parameter	Symbol	Maximum Rating	Unit
Peak Forward Current	IFp	350	mA
Forward Current	IF	300	mA
Reverse Voltage	VR	5	V
Power Dissipation	PD	1	W
Operating Temperature	Topr	-40~+85	°C
Storage Temperature	Tstg	-40~+85	°C
Electrostatic Discharge	ESD	500	V

Lead soldering Temperature (4mm from body) : 260°C for seconds

Optical-Electrical Characteristic: (TA=25°C)

Parameter	Symbol	Condition	Min	Type	Max	Unit
Forward Current	VF	IF=300mA	3.0	-	3.6	V
Reverse Current	IR	VR=5V		-	5	uA
Chromaticity Coordinates	X	IF=300mA	0.28	0.30	0.32	nm
Chromaticity Coordinates	Y	IF=300mA	0.29	0.31	0.32	nm
CCT	Tc	IF=300mA	6000	-	8000	K
Flux	Φ	IF=300mA	60	-	64	Lm
Luminous Efficacy	Iv	IF=300mA	60	-	63	Lm/W
Viewing Angle	2θ1/2	IF=300mA	-	120	-	Deg

Fig. 1

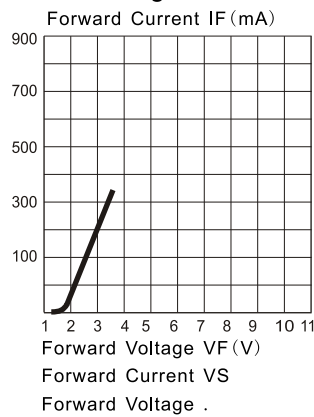

Fig. 2

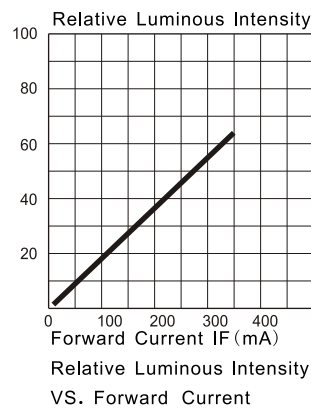

Fig. 3

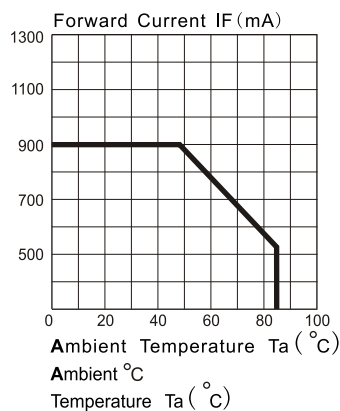
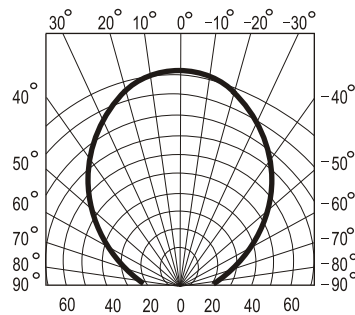

Fig. 4



NOTES: 1. All dimensions are in millimeter (inches), tolerance is 0.25 unless otherwise noted.
2. Specifications are subject to change without notice.