

FL77PGC

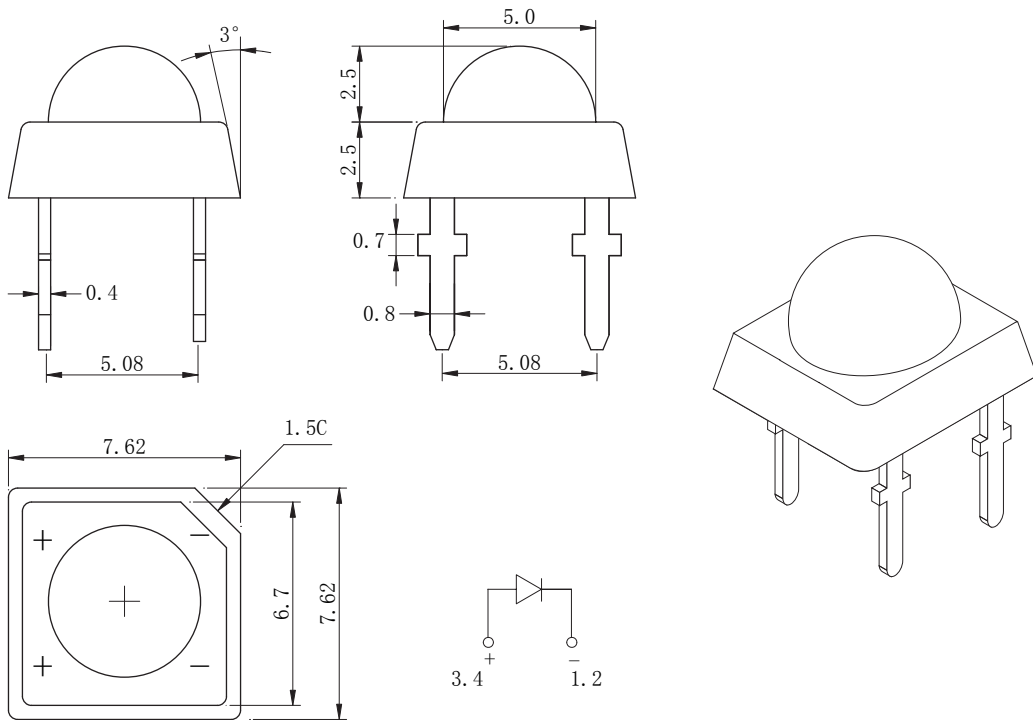

Unit: mm

Dice	Green (InGaN/SiC)	Lens Type	Water Clear
------	---------------------	-----------	-------------

Absolute Maximum Rating at (Ta=25°C)

Parameter	Symbol	Maximum Rating	Unit
Power Dissipation	Pd	80	mW
Forward Current	If	20	mA
Peak Forward Current Per chip *	Ifp	100	mA
Operating Temperature Range	Topr	- 25 °C to + 80 °C	
Storage Temperature Range	Tstg	- 5 °C to + 45 °C	
Solder Temperature 1/16 Inch Below Seating Plane for 5 seconds at 260 °C			

* Condition for Ifp is pulse of 1/10 Duty Cycle, 0.1ms Pulse Width

Electrical/Optical Characteristics at Ta=25°C

Parameter	Symbol	Condition	Min	Typ	Max	Unit
Forward Voltage	Vf	If=20mA	2.8	3.2	3.6	V
Reverse Current	Ir	Vr=5V			20	uA
Luminous Intensity	Iv	If=20mA	800	1200		mcd
Prpc Wavelength	λD	If=20mA	515		520	nm
		If=20mA				nm
Half View Angle	2Θ1/2	If=20mA		80		deg

NOTES: 1. All dimensions are in millimeter (inches) , tolerance is 0.25 unless otherwise noted.
2. Specifications are subject to change without notice.