

FL75BC

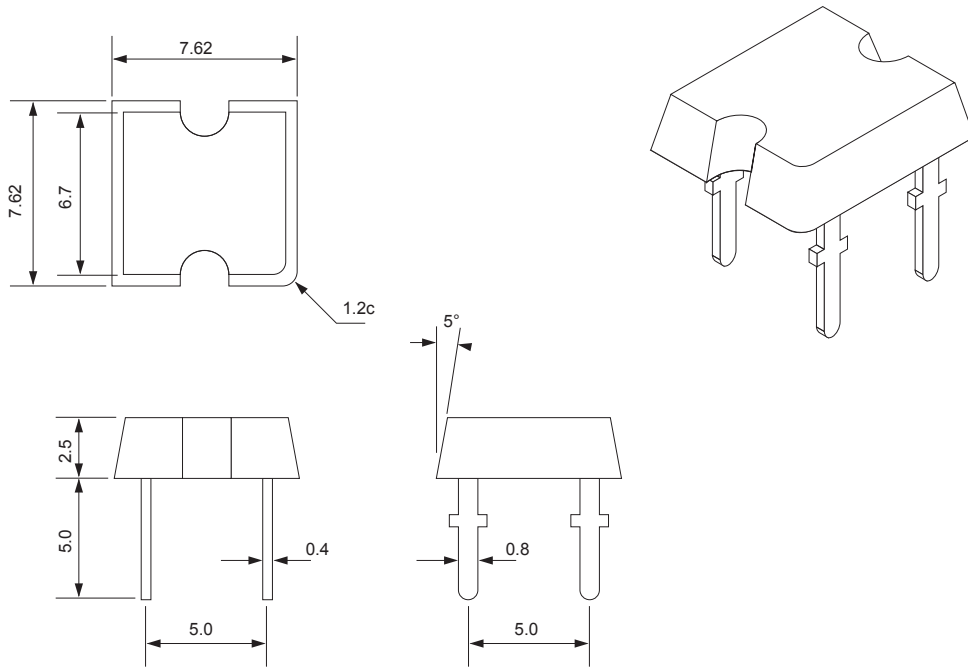

Unit: mm

- * Blue Color Dice.
- * Encapsulated with Water Clear Package.

Absolute Maximum Ratings.

Parameter	Symbol	Maximum Rating	Unit
Power Dissipation	Pd	40	mW
Peak Forward Current	I _{fp}	160	mA
Continuous Forward Current	I _f	20	mA
Operating Temperature Range	T _{opr}	-25°C to +80°C	
Storage Temperature Range	T _{stg}	-40°C to +80°C	
Lead Soldering Temperature	T _{stg}	260°C for 5 seconds	

* IFP Conditions: Pulse width \leq 10 msec duty \leq 1/10 * T_{sol} Conditions: 3mm from the base of the epoxy bulb.

Electro-Optical Characterature (T_a=25°C)

Parameter Radiant	Test Condition	Symbol	Min.	Typ.	Max.	Unit
Forward Voltage	I _f =20mA	V _f		3.2	3.8	V
Reverse Current	V _r =5V	I _r			10	uA
Luminous Intensity	I _f =20mA	I _v		550		mcd
Spectral Bandwidth	I _f =20mA	$\Delta\lambda$				nm
Wavelength	I _f =20mA	λ_p		470		nm
		λ_d				nm
Half View Angle	I _f =20mA	2 θ 1/2		120		deg

1. Absolute maximum ratings T_a=25°C

2. Tolerance of measurement of forward voltage \pm 0.1V

3. Tolerance of measurement of peak Wavelength \pm 2.0nm

4. Tolerance of measurement of luminous intensity \pm 15%